

ASSEMBLY STEP 2

HARDWARE USED IN THIS STEP

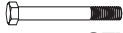

Bolts(A) QTY: 2
HBOLT 0.375-13 2.75



Washers(B) QTY: 2
FW 0.375

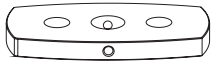

WEIGHT STACK (10LB)
QTY: 19

NOTE: During each assembly step, ensure that all bolts and nuts are in place and partially threaded

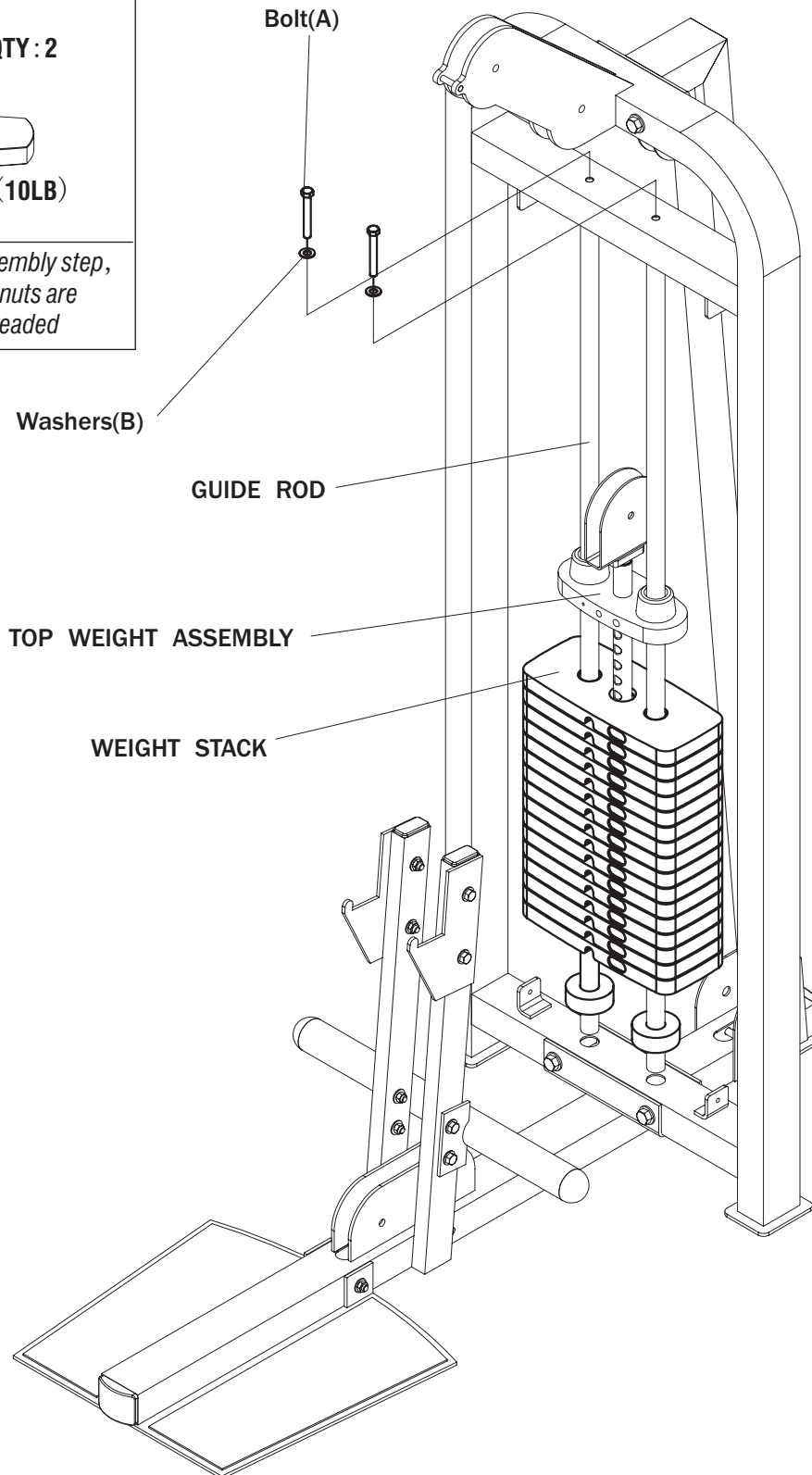

ASSEMBLY STEP 3

HARDWARE USED IN THIS STEP

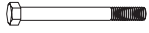

Bolts(A) QTY: 1
HBOLT 0. 375-16 3.5



Nuts(E) QTY: 8
HJNUT 0. 375-16

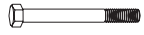

Bolts(B) QTY: 1
HBOLT 0. 375-16 3.25



Washers(F) QTY: 14
FW 0. 375



Bolts(C) QTY: 2
HBOLT 0. 375-16 2.25



TOW SNAP LINKS
QTY: 2



Bolts(D) QTY: 4
HBOLT 0. 375-16 2

NOTE: During each assembly step, ensure that all bolts and nuts are in place and partially threaded in before completely any one bolt.

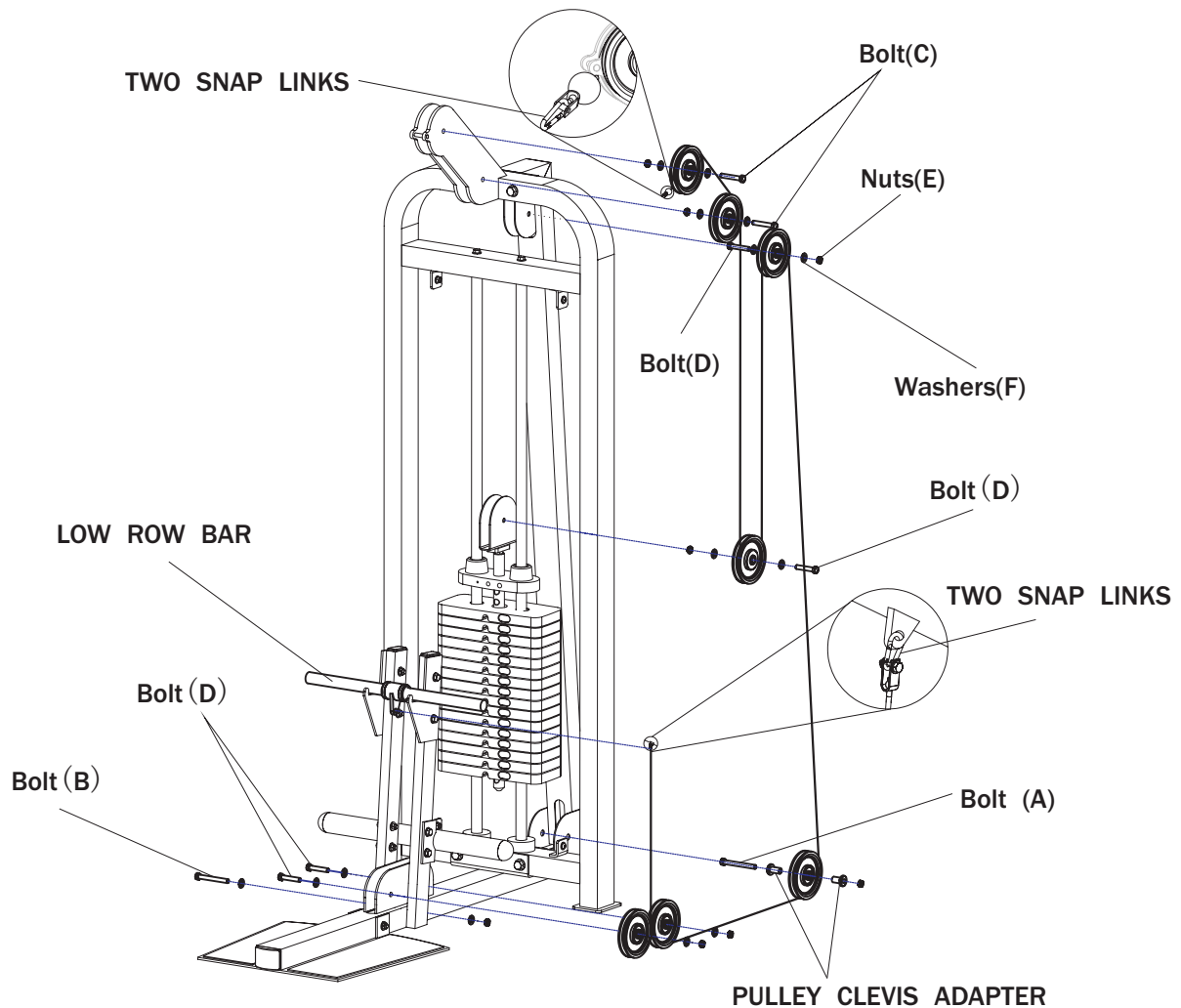

ASSEMBLY STEP 4

HARDWARE USED IN THIS STEP



Bolts(A) QTY: 4
SBHCSCREW 0. 315-18 0. 75



Nuts(B) QTY: 4
HJNUT 0. 315-18



Washers(C) QTY: 8
FW 0. 315

NOTE: During each assembly step, ensure that all bolts and nuts are in place and partially threaded in before completely any one bolt.

